



**59/325/CD**

**COMMITTEE DRAFT (CD)**

IEC/TC or SC: TC 59	Project number IEC 62301 Ed 1.0	
Title of TC/SC: Performance of household electrical appliances	Date of circulation <b>2003-03-07</b>	Closing date for comments <b>2003-06-13</b>
Also of interest to the following committees TC100, TC108	Supersedes document 59/297/CD and 59/317A/CC	
Functions concerned: <input type="checkbox"/> Safety <input type="checkbox"/> EMC	<input checked="" type="checkbox"/> Environment	<input type="checkbox"/> Quality assurance
Secretary: Peter Riller E-mail: m.p.riller@t-online.de	THIS DOCUMENT IS STILL UNDER STUDY AND SUBJECT TO CHANGE. IT SHOULD NOT BE USED FOR REFERENCE PURPOSES.  RECIPIENTS OF THIS DOCUMENT ARE INVITED TO SUBMIT, WITH THEIR COMMENTS, NOTIFICATION OF ANY RELEVANT PATENT RIGHTS OF WHICH THEY ARE AWARE AND TO PROVIDE SUPPORTING DOCUMENTATION.	

Title:  
IEC 62301 Ed 1.0: Measurement of Standby Power

(Titre) :

Introductory note

This draft was prepared by TC 59/WG 9 (Measurement of standby power).

**Copyright © 2003 International Electrotechnical Commission, IEC.** All rights reserved. It is permitted to download this electronic file, to make a copy and to print out the content for the sole purpose of preparing National Committee positions. You may not copy or "mirror" the file or printed version of the document, or any part of it, for any other purpose without permission in writing from IEC.

# CONTENTS

	Page
INTRODUCTION .....	4
1 Scope.....	5
1.1 Normative References .....	5
2 Definitions .....	5
3 General conditions for measurements .....	6
3.1 General .....	6
3.2 Test room .....	6
3.3 Power supply .....	6
3.4 Supply voltage waveform .....	7
3.5 Power Measurement Accuracy .....	7
4 Measurements .....	7
4.1 General .....	7
4.2 Selection and preparation of appliance or equipment .....	7
4.3 Procedure .....	8
4.3.1 Where the selected mode is stable .....	8
4.3.2 All other measurements .....	8
5 Test report.....	8
5.1 Appliance (equipment) details: .....	8
5.2 Test Parameters .....	9
5.3 Measured data, for each mode as applicable: .....	9
5.4 Test and laboratory details .....	9
Annex A (Informative) Some typical modes for selected appliance types .....	10
Annex B (Informative) Notes on the measurement of low power modes .....	13
Annex C (Informative) Converting power values to energy .....	15
Annex D (Informative) Determination of Uncertainty of Measurement .....	16
Annex E (Informative) Bibliography .....	17

## INTERNATIONAL ELECTROTECHNICAL COMMISSION

---

**HOUSEHOLD ELECTRICAL APPLIANCES -  
Measurement of Standby Power**

## FOREWORD

- 1) The IEC (International Electrotechnical Commission) is a worldwide organization for standardization comprising all national electrotechnical committees (IEC National Committees). The object of the IEC is to promote international co-operation on all questions concerning standardization in the electrical and electronic fields. To this end and in addition to other activities, the IEC publishes International Standards. Their preparation is entrusted to technical committees; any IEC National Committee interested in the subject dealt with may participate in this preparatory work. International, governmental and non-governmental organizations liaising with the IEC also participate in this preparation. The IEC collaborates closely with the International Organization for Standardization (ISO) in accordance with conditions determined by agreement between the two organizations.
- 2) The formal decisions or agreements of the IEC on technical matters express, as nearly as possible, an international consensus of opinion on the relevant subjects since each technical committee has representation from all interested National Committees.
- 3) The documents produced have the form of recommendations for international use and are published in the form of standards, technical specifications, technical reports or guides and they are accepted by the National Committees in that sense.
- 4) In order to promote international unification, IEC National Committees undertake to apply IEC International Standards transparently to the maximum extent possible in their national and regional standards. Any divergence between the IEC Standard and the corresponding national or regional standard shall be clearly indicated in the latter.
- 5) The IEC provides no marking procedure to indicate its approval and cannot be rendered responsible for any equipment declared to be in conformity with one of its standards.
- 6) Attention is drawn to the possibility that some of the elements of this International Standard may be the subject of patent rights. The IEC shall not be held responsible for identifying any or all such patent rights.

International Standard IEC 62301 has been prepared by working group 9 of IEC Technical Committee TC59:

The text of this standard is based on the following documents:

FDIS	Report on voting
XX/XX/FDIS	XX/XX/RVD

Full information on the voting for the approval of this standard can be found in the report on voting indicated in the above table.

This publication has been drafted in accordance with the ISO/IEC Directives, Part 3.

The committee has decided that this publication remains valid until \_\_\_\_\_. At this date, in accordance with the committee's decision, the publication will be

- reconfirmed;
- withdrawn;
- replaced by a revised edition, or
- amended.

## INTRODUCTION

The original proposal for a new standard on standby was prepared by the TC 59 ad-hoc WG on standby. This was submitted as a new work item proposal (document IEC 59/254/NP) in May 2001. This proposal was approved (see IEC 59/270/RVN) in September 2001 (project number IEC 62301) and at its meeting in Florence in October 2001, TC59 approved the creation of Working Group 9 to continue this work to publication. Working Group 9 finalized the committee draft at its meeting in March 2002 and this was issued in July 2002 for public comment (document IEC 59/297/CD). The compilation of comments on the CD was issued as document IEC 59/317/CC in November 2002. This second Committee Draft (2<sup>nd</sup> CD) was prepared on the basis of the comments received on the CD and subsequent consultation with WG9-members. At the end consensus seemed to be reached, but TC59 decided to submit a second CD instead of a Committee Draft for Voting, because of late concerns announced after the closing date of the first CD and in order to avoid disagreement during the final voting of a CDV.

The objective of this draft standard is to provide a method of test to determine the power consumption of a range of appliances and equipment in standby mode (generally where the product is not performing its main function). This standard defines “standby” mode as the lowest power consumption when connected to the mains. The test method is also applicable to other low power modes where the mode is steady state or providing a background or secondary function (e.g. monitoring or display). An Annex provides some guidance on the expected modes that would be found for various appliance configurations and designs based on their circuitry and layout, but the standard does not define these modes.

At its October 2001 meeting, TC59 agreed that product committees should be primarily responsible for the definition of the relevant low power modes (in addition to standby mode) to which this test procedure is applied.

The methods defined are not intended to be used to measure power consumption of appliances and equipment during normal operation (“on” mode), as these are generally covered by IEC product standards (see Annex E – Bibliography). This standard is intended to cover appliances and equipment that fall within the scope of IEC TC59, although it is acknowledged that, if desired, it can be applied to the relevant low power modes of other similar products.

# HOUSEHOLD ELECTRICAL APPLIANCES - Measurement of Standby Power

## 1 Scope

This International Standard specifies methods of measurement of electrical power consumption in standby mode. It is applicable to mains powered electrical household appliances and to the mains powered parts of appliances that use other fuels such as gas or oil.

This Standard does not specify safety requirements. It does not specify minimum performance requirements nor does it set maximum limits on power or energy consumption.

NOTE 1 – This standard may be applicable to other low power modes.

NOTE 2 - The measurement of energy consumption and performance of appliances during intended use are generally specified in the relevant product standards and are not intended to be covered by this standard.

NOTE 3 – The term “appliances” in this standard means household appliances or equipment.

### 1.1 Normative References

ISO Guide to the Expression of Uncertainty in Measurement, ISBN 92-67-10188-9.

IEC 60050 International Electrotechnical Vocabulary - Electrical and electronic measurements and measuring instruments

Part 131: Electric and magnetic circuits

Part 311: General terms relating to measurements

Part 312: General terms relating to electrical measurements

Part 313: Types of electrical measuring instruments

## 2 Definitions

For the purpose of this Standard the following definitions apply. Terms defined in IEC 60050 International Electrotechnical Vocabulary also apply.

### 2.1

#### **Standby mode**

the lowest power consumption mode which cannot be switched off (influenced) by the user and that may persist for an indefinite time when an appliance is connected to the main electricity supply and used in accordance with the manufacturer's instructions.

Note: The standby mode is usually a non-operational mode when compared to the intended use of the appliance's primary function.

### 2.2

#### **Standby power**

Average power in standby mode when measured in accordance with clause 4.

The standby power is measured in Watts.

### 2.3

#### Rated power

input power assigned to the appliance by the manufacturer.

### 2.4

#### Rated voltage

voltage assigned to the appliance by the manufacturer.

### 2.5

#### Rated frequency

frequency assigned to the appliance by the manufacturer.

## 3 General conditions for measurements

### 3.1 General

Unless otherwise specified, measurements shall be made under test conditions and with equipment specified in clauses 3.2 to 3.5.

### 3.2 Test room

The tests shall be carried out in a room that has an air speed close to the appliance under test of  $\leq 0.5$  m/s. The ambient temperature shall be maintained at  $(23 \pm 5)$  °C throughout the test.

Note: The measured power for some products and modes may be affected by the ambient conditions (e.g. illuminance, temperature).

### 3.3 Power supply

The test voltage shall be the rated voltage  $\pm 1\%$  and the test frequency shall be the rated frequency  $\pm 1\%$ .

If a voltage and/or frequency range is specified by the manufacturer (or the rated value is unclear), the appliance shall be tested at the nominal voltage and the nominal frequency of the country for which the measurement is being determined  $\pm 1\%$  (refer Table 1).

**Table 1: Typical nominal electricity supply details for some regions**

Country/Region	Nominal Voltage and Frequency *
Europe	230 V, 50 Hz
North America	115 V, 60 Hz
Japan **	100 V, 50/60 Hz
Australia and New Zealand	230 V, 50 Hz

Notes: \* Values are for single phase only. Some single phase supply voltages can be double the nominal voltage above (centre transformer tap). The voltage between two phases of a three phase system are 1.73 times single phase values.

\*\* "50 Hz" is applicable for the Northern part; "60 Hz" is applicable for the Southern part respectively.

### 3.4 Supply voltage waveform

The total harmonic content of the supply voltage when supplying the appliance under test in the specified mode shall not exceed 2% (up to and including the 13<sup>th</sup> harmonic); harmonic content is defined as the root-mean-square (r.m.s.) summation of the individual components using the fundamental as 100%.

The ratio of peak value to RMS value of the test voltage (i.e. crest factor) shall be between 1,34 and 1,49.

### 3.5 Power Measurement Accuracy

Measurements of standby power of 0.5 Watt or greater shall be made with an uncertainty of less than or equal to 2% at the 95% confidence level. Measurements of standby power of less than 0.5 Watt shall be made with an uncertainty of less than or equal to 0.01 Watt at the 95% confidence level. The power measurement instrument shall have a resolution of 0.01W or better for standby power.

Note: See Annex D and ISO Guide to the Expression of Uncertainty in Measurement for further details.

## 4 Measurements

### 4.1 General

The purpose of this test method is the determination of the standby power, which in principle persists for an indefinite period of time. However, it is considered sufficient to measure over a limited period of time as given in 4.3.

Note 1: Some appliances may wait in a higher power state after they are switched off (or after the power is first connected) before dropping back to a lower state, or they may take some time to drop back to a lower state.

Note 2: Where the mode changes automatically, it may be necessary to operate a product through the automatic sequence several times on a trial basis to ensure that sequence is fully understood and documented before test results are recorded and reported. Refer to Annex B for further guidance.

Under this standard, standby power consumption may be determined:

- Where the power value is stable, by recording the instrument power reading; or
- Where the standby power value is not stable, by averaging the instrument power readings over a specified period or, alternatively by recording the energy consumption over a specified period and dividing by the time.

Note: Determination of an average power from accumulated energy over a time period is equivalent. Energy accumulators are more common than functions to average power over a user specified period.

### 4.2 Selection and preparation of appliance or equipment

Tests in this standard are to be performed on a single appliance.

The appliance shall be prepared and set up in accordance with the manufacturer's instructions, except where these conflict with the requirements of this standard. If no instructions are given, then factory or "default" settings shall be used, or where there are no indications for such settings, the appliance is tested as supplied.

For portable appliances with a rechargeable battery, standby mode is measured on the charger or docking/base station with the appliance detached.

Note: For the purposes of this test procedure, a portable appliance is one that is intended to operate on rechargeable batteries when not connected to a power source.

## 4.3 Procedure

### 4.3.1 Where the selected mode is stable

This methodology may only be used where the mode and measured power are stable. A variation of less than 5% in the measured power over 5 minutes is considered stable for the purposes of this standard. Instrument power readings may be used in this case.

Connect the product to be tested to the metering equipment, and select the mode to be measured. After the product has been allowed to stabilize for at least 5 minutes, monitor the power consumption for not less than an additional 5 minutes. If the power level does not drift by more than 5% (from the maximum value observed) during the later 5 minutes, the load can be considered stable and the power can be recorded directly from the instrument at the end of the 5 minutes.

### 4.3.2 All other measurements

This methodology shall be used where either the mode or measured power is not stable. However, it may also be used for all stable modes and is the recommended approach if there is any doubt regarding the behaviour of the appliance or stability of the mode. Average power readings or accumulated energy over a user-selected period are used in this case.

Connect the appliance (equipment) to the metering equipment. Select the mode to be measured (this may require a sequence of operations and it may be necessary to wait for the equipment to automatically enter the desired mode) and monitor the power. Average power is determined using either the **average power** or **accumulated energy** approaches outlined below.

**Average power approach:** where the instrument can record a true average power over a user selected period, the period selected shall not be less than 5 minutes (except if there is an operating cycle – see below).

**Accumulated energy approach:** where the instrument can accumulate energy over a user selected period, the period selected shall not be less than 5 minutes (except if there is an operating cycle – see below). The integrating period shall be such that the total recorded value for energy and time is more than 200 times the resolution of the meter for energy and time. Determine the average power by dividing the accumulated energy by the time for the monitoring period.

Note 1 - To ensure consistent units, it is recommended that Wh and hours be used above, to give Watts.

Note 2: Example 1 - if an instrument has a time resolution of say 1 second, then a minimum of 200 seconds (3.33 minutes) is required for integration on such an instrument. Example 2 - if an instrument has an energy resolution of say 0.1 mWh, then a minimum of 20 mWh is required for an integration on such an instrument (at a load of 0.1 W, this would take about 12 minutes, at 1 Watt, this would take 1.2 minutes). Note that both the time and energy resolution requirements have to be satisfied by the reading.

If the power varies over a cycle (i.e. a regular sequence of power states that occur over several minutes or hours), the period selected to average power or accumulate energy shall be one or more complete cycles in order to get a representative average value.

In case of accumulated energy the integrating period shall be as described above.

## 5 Test report

The following information shall be recorded in the test report:

### 5.1 Appliance (equipment) details:

- brand, model, type, and serial number.
- product description, *as appropriate*
- rated voltage(s) and frequency(frequencies)
- details of manufacturer

**5.2 Test Parameters**

- ambient temperature (°C).
- test voltage(s) (V) and frequency (frequencies) (Hz).
- total harmonic distortion of the electricity supply system
- information and documentation on the instrumentation, set-up and circuits used for electrical testing.

**5.3 Measured data, for each mode as applicable:**

- average power in Watts rounded to the second decimal place. For loads greater than or equal to 10 Watts, three significant figures shall be reported.
- measurement method used (refer clause 4.3.1 and 4.3.2) (in the case of 4.3.2, indicate whether average power or accumulated energy approach was used)
- accumulated energy and period of measurement (seconds/minutes/hours) (if applicable)
- description of how the appliance mode was selected or programmed
- sequence of events to reach the mode where the equipment automatically changes modes
- any notes regarding the operation of the *appliance* (equipment).

**5.4 Test and laboratory details**

- test report number/reference
- date of test
- laboratory name and address
- test officer(s)

## Annex A (Informative)

### Some typical modes for selected appliance types

#### A1 Background

This Annex sets out in diagrammatic form some common appliance configurations and whether these are likely to have some standby power consumption or other associated low power modes. The major components in the appliance that affect power consumption are described below together with some examples and descriptions for each type (A to G).

#### A2 Subsidiary Function(s)

This is a module that performs some function(s) that are ancillary to the primary load. Subsidiary functions will usually consume small amounts of power. Some subsidiary functions may have a separate switch to disconnect them from the supply. Subsidiary functions are shown as SUB in Figure A1. Examples of subsidiary functions are:

- remote control of power to the operating load (effectively a remote power switch);
- automatic disconnection of the load on completion (auto off power switch);
- display (could be mode, program, state or clock etc.);
- low voltage power supply for memory and clock functions;
- low voltage power supply for electronic controls and switches;
- electromagnetic compatibility (EMC) filters;
- running a cooling fan or auxiliaries.

#### A3 Power switch

This allows the user to turn an appliance (or the operating load) ON or OFF. There are a number of variations of a power switch as follows:

- *All off power switch*: Results in the same state as being unplugged from the power supply when the switch is turned OFF.
- *Auto power off switch*: Turns 'ON' manually and turns 'OFF' automatically after finishing operation.
- *Power control switch*: A power switch that incorporates some sort of power control device such as a dimmer or thyristor.

#### A4 Operating load

This is the main function of the appliance. Thermostats or temperature control devices to control the operating load are usually considered as part of the operating load.

#### A5 Appliances Types

Figure A1 depicts a number of common appliance types. A brief description of each type and some examples are given below. The example products listed are to illustrate those typical household products that are configured in a particular way and their inclusion is not necessarily related to the scope of this standard.

Note: Letters allocated to each appliance type are arbitrary.

**Type A:** The appliance has no subsidiary load and no power switch. The appliance operates whenever plugged in. There may be some internal regulation of the load (eg thermostat or temperature control device). There is no standby power.

Examples of Type A appliances: electric kettles (with no cut-out), some small kitchen appliances, electric storage water heaters, refrigerators.

**Type B:** The appliance has a power switch. The appliance operates when it is manually turned on by the power switch and stops when turned off. Power switches can be the auto-off type (automatically turns off at the completion of the operation). There is no standby power.

Examples of Type B appliances: electric heaters (with no thermostat), hair dryers, toasters, electric kettles (with boil cut-out), some major appliances (some dishwashers, clothes washers and clothes dryers), many small kitchen appliances, cooktops, some ovens.

**Type C:** The appliance has no (hard) power switch but has a subsidiary function that controls the operating load or performs some related function. There may be a remote control or electronic power switch. Standby power may be associated with the subsidiary function.

Examples of Type C appliances: bread makers, some small kitchen appliances, some major appliances (some dishwashers, clothes washers and clothes dryers), some microwave ovens, any appliance with a remote control and no hard off switch, any appliance with a "soft" (electronic) power switch.

**Type D:** The appliance has a power switch that disconnects the operating load and has a subsidiary function that is permanently connected to the power. Standby power may be associated with the subsidiary function.

Examples of Type D appliances: conventional ovens, some types of heaters, VCRs, any appliance that requires some power for a subsidiary function (clock, display, etc.).

**Type E:** The appliance has a power switch that disconnects the operating load. It may have a subsidiary function that is permanently connected to the power and/or one that is disconnected with the power switch. Standby power may be associated with the permanently connected subsidiary function. Other low power modes may be associated with the switched subsidiary function.

Examples of Type E appliances: some microwave ovens, some major appliances (some dishwashers, clothes washers and clothes dryers), some types of heaters, any appliance that requires some power for a subsidiary function (clock, display, etc.), TVs, any appliance with permanently connected electronics or EMC filters.

**Type F:** The appliance has an external power supply that provides the appliance with power for its primary operation. Supply is usually extra low voltage (< 50V) and may be AC or DC and may be connected via a plug. Appliance configuration may be A to E above. Standby is associated with the power supply and there may be numerous low power modes.

Examples of Type F appliances: any appliance with an external power supply required for normal operation, some toys, some phones and answering machines.

**Type G:** The appliance has an external power supply that provides the appliance with power mainly for battery charging. The appliance primary operation is normally performed disconnected from the power supply (battery operated and portable appliances), but some may be used with the power supply connected. Supply is usually extra low voltage (< 50V) and may be AC or DC and is connected via a detachable plug. Standby is associated with the power supply and there are low power modes associated with battery charging and use.

Examples of Type G appliances: portable battery operated appliances such as battery shavers, electric toothbrushes, portable vacuum cleaners.

Figure A.1 Circuit diagram images by type

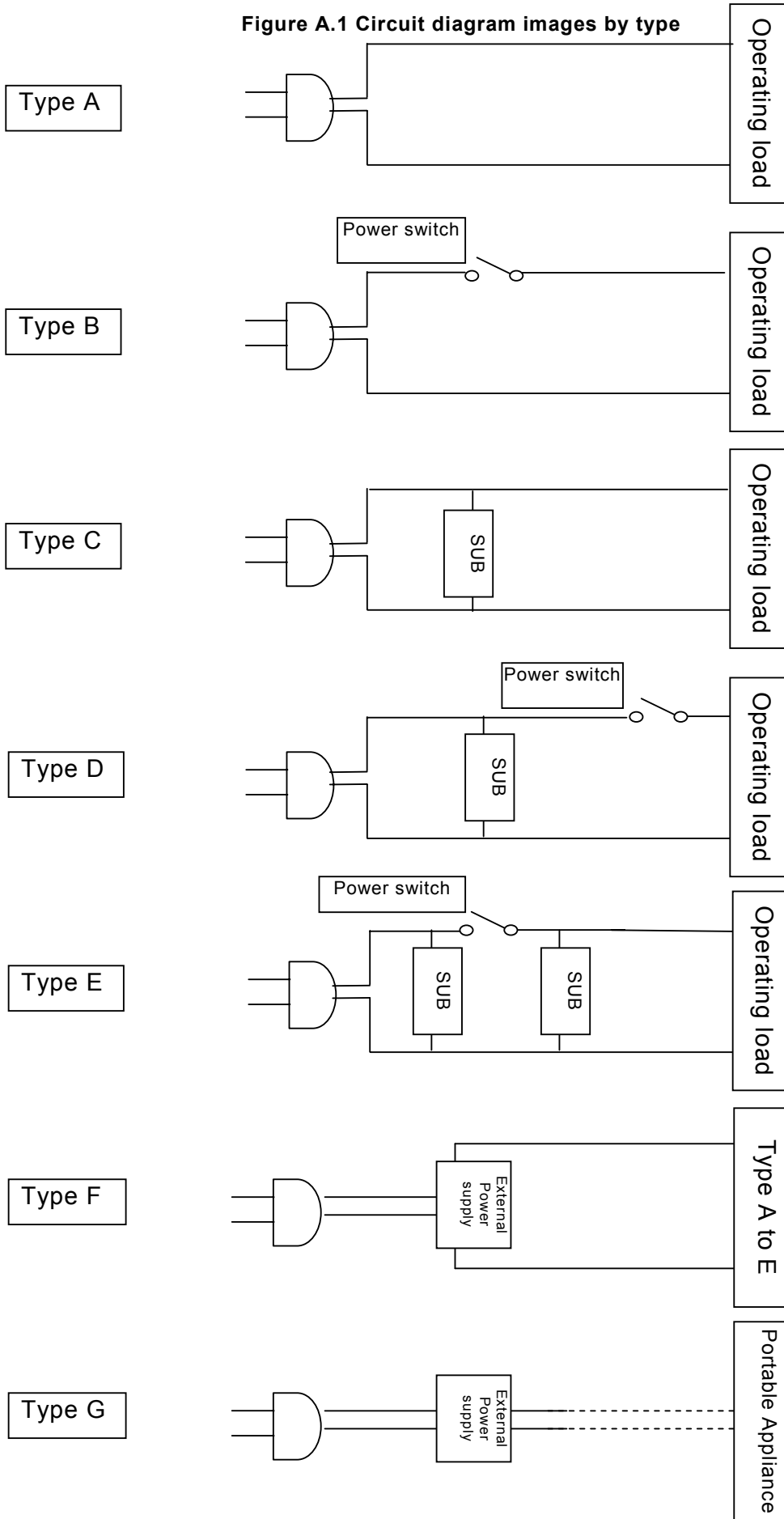

## **Annex B**

(Informative)

### **Notes on the measurement of low power modes**

There are a number of problems associated with power measurement of very small loads that are typically found in standby and other low power modes (typically less than 10 Watts). These mostly relate to the ability of the measurement instrument to respond correctly to current waveform that is presented. Key points for consideration are discussed briefly below.

#### **B1 Standby Power**

The intent of this standard is to measure power of the device in the specified mode. However in many low power modes, the current waveform is unlikely to be sinusoidal, so it is necessary to ensure that the meter has a scanning frequency that is sufficiently fast to capture the unusual current waveforms that are common (such as pulses or spikes). To determine the power, the meter has to multiply the instantaneous current and voltage values several hundred times per cycle (roughly 15 milliseconds). Most digital instruments accumulate these values and display an average power once or twice a second. It is important to note that the power of many products in low power modes will be less than 10 Watts (some will be very small). This is partly due to low current levels, but also, in some cases, due to the current waveform being largely unrelated to the voltage waveform.

#### **B2 Crest Factor**

The crest factor is defined as the ratio of peak current to RMS current (or peak voltage to RMS voltage). For a pure sinusoidal waveshape the crest factor is 1.414, while for a pure constant DC load the crest factor is 1.0. In normal circumstances it is assumed that the voltage supply impedance will be such that the voltage waveform will remain generally sinusoidal in shape when supplying small standby loads (noting the allowable harmonic requirements for the electricity supply in Clause 3.4), so the parameter of particular concern from a metering perspective is usually current and its waveform. During the measurement, it is critical that the crest factor capability of the meter is greater than the actual crest factor of the load, otherwise the peak value of the current will be “lopped off” and the integration for power will be incorrect. Most meters will have a rated crest factor stated for the rated input within each “range”. Usually, the available crest factor will increase as the actual load becomes smaller relative to the rated input range selected. However, if the range selected is too large, the accuracy resolution of the measurement will become poor. Good meters will give an “out of range” reading if the available crest factor is exceeded. Note that crest factors for standby loads are typically 3 and can, in some circumstances, be as high as 10. Good instruments will provide guidance on how to deal with high crest factor loads while retaining measurement accuracy.

#### **B3 Instruments for Power Measurements**

Generally, a digital power analyser with a fundamental power accuracy of 0.5% or better will comfortably meet the instrument specification and measurement uncertainty required in this standard. It is not usually possible to meet these requirements (either the required accuracy or the measurement method) using traditional rotating disk kWh meters. Low power loads (less than 10W) are often unable to overcome the starting torque required for the operation of a rotating disk meter and such loads may therefore appear as 0 Watts. This is unsatisfactory.

The following broad recommendations are made regarding power measurement instruments:

- Power resolution of 1 mW or better;
- An available current crest factor of 3 (or more) at its rated range value;
- Minimum current range of 10mA (or less).

It is also desirable for measurement instruments to be able to average power accurately over any user selected time interval (this is usually done with an internal math's calculation dividing accumulated energy by time within the meter, which is the most accurate approach). As an alternative, the measurement instrument would have to be capable of integrating energy over any user selected time interval with an energy resolution of less than or equal to 0.1 mWh and integrating time displayed with a resolution of 1 second or less.

#### **B4 Harmonic components of the current waveform**

Where the current waveform is a smooth sine wave in phase with the voltage waveform (e.g. in a resistive heating load), there is no harmonic content in the current waveform. However, some current waveforms associated with low power modes are highly distorted and the current may appear as a series of short spikes or a series of pulses over a typical AC cycle. This effectively means that the current waveform is made up of a number of higher order harmonics which are multiples of the fundamental frequency (50Hz or 60Hz). Most digital power analysers will have no problem with the accurate measurement of higher order current harmonics presented by low power modes. However, it is recommended that a power instrument should have the ability to measure harmonic components up to at least 2.5 kHz. Note that harmonic components greater than the 49th harmonic (2450 Hz) generally have little power associated with them. As a rule, the scanning frequency of a power measurement instrument should be at least twice the frequency of the highest order harmonic that has significant power associated with it.

#### **B5 Cyclic or pulsing load effects**

Some loads on standby may be cyclic or pulsing in nature. Such loads make it impossible to use normal power readouts from a power meter to determine standby power. In these cases it is necessary to use either a meter that can provide a true power average over a reasonable period selected by the user (a minimum of five minutes is required by this standard), or to integrate energy over a period of several minutes (not less than 5 minutes, but the minimum time depends on the time and energy resolution of the meter and the magnitude and nature of the load).

Some loads are cyclical in nature in that they may be stable for a period (often many minutes) and may then go into a higher or lower energy state for a short period (say to run a heater or recharge some capacitors, or to turn some components off or on temporarily). Some products may draw a power pulse at infrequent intervals. In these cases, it is important to understand the behaviour of the product before measurements are commenced. Where there is a "regular" cycle of differing energy states, then a whole number of cycles should be examined when determining average power. To gain a better understanding of the product behaviour it can be useful to examine the load profile with an oscilloscope that is set to trigger on a significant change of load.

#### **B6 Asymmetric current waveforms (DC components)**

Depending on the power supply configuration and design, some small loads (such as those associated with standby) can draw asymmetric current; that is drawing current only on either the positive or negative part of the AC voltage cycle. This is effectively a DC power load component supplied by an AC voltage supply. Most digital power analysers can adequately handle low frequency and DC components during a power measurement. However, it is not possible to undertake accurate measurements of this type of current waveform using any type of transformer input such as a current transformer – DC components are not visible through a transformer input. It is therefore critical that any power instrument uses a direct shunt input to measure current. DC loads also exert a braking torque on rotating disc meters, making them unsuitable for any size load of this type.

## Annex C (Informative)

### Converting power values to energy

#### General

This annex provides some guidance regarding the conversion of power measurements determined under this standard to energy consumption values.

Energy is the average power multiplied by the time. Electrical energy is generally expressed in Wh or kWh. Energy can also be expressed in Joules. One Watt is the rate of energy consumption of 1 Joule per second. 1 kWh is equivalent to 3.6 MJ.

To convert power to energy (e.g. an annual energy consumption), the number of hours of operation in each mode must be assumed for a given period and the average power for each mode must also be known. As most appliances can operate in a number of modes and the usage patterns and profiles may vary considerably between countries, converting power values determined under this standard to energy values is potentially fraught with difficulty.

In the simplest case, an appliance that has only a single mode of operation can be converted to an annual energy value by assuming a constant power for a whole year. A year has 8,760 hours (this ignores leap years), so an appliance that has say a constant standby power of 5 Watts (assuming that there is no use in other modes) would consume 43,800 Wh per year or 43.8 kWh per year.

Annual energy consumption can be determined for more complex user patterns by the sum of power  $\times$  time for each mode for hours in the year (i.e. hours 1 to 8,760).

When total energy consumption for a large appliance is being considered, it is necessary to know as a minimum the “on” mode time and energy consumption per cycle, an assumed number of uses (cycles) per year and the “standby” (usually off mode) power.

**Example 1:** Say a clothes washer has a program time of 85 minutes and an energy consumption of 0.95 kWh per cycle and a standby power consumption (off mode) of 1.30 Watts. The annual energy consumption for 300 uses per year would be (assuming no use of delay start and assuming end of program power is equal to the standby power consumption):

Time in use =  $85 \times 300 \div 60 = 425$  hours per year

Time in standby =  $8760 - 425 = 8335$  hours per year

Energy consumption in use =  $300 \times 0.95 = 285$  kWh per year

Energy consumption in standby =  $8335 \times 1.30 \div 1000 = 10.836$  kWh per year

Energy consumption total =  $10.836 + 285 = 295.836$  kWh per year

**Example 2:** Say a breadmaker takes 4 hours to bake a standard 700g loaf of bread and uses 0.33 kWh in the process. It is used to bake three loaves a week. The rest of the time it is left plugged in. It has a standby power consumption of 2 Watts. The annual energy consumption for 156 uses per year would be:

Time in use =  $4 \times 3 \times 52 = 624$  hours per year

Time in standby mode =  $8760 - 624 = 8136$  hours per year

Energy consumption in use =  $0.33 \times 52 \times 3 = 51.48$  kWh per year

Energy consumption in standby =  $8136 \times 2.0 \div 1000 = 16.272$  kWh per year

Energy consumption total =  $16.272 + 51.48 = 67.752$  kWh per year

## **Annex D**

(Informative)

### **Determination of Uncertainty of Measurement**

The following text has been adapted from “Assessment of Uncertainties of Measurement” by RR Cook, published by NATA Australia, 1999, ISBN 0-909307-46-6. Further detail should be obtained from this reference or the ISO “Guide to the Expression of Uncertainty in Measurement”.

Any measurand (the subject of a measurement) will have a true value that will be approximated by the measurement value. The error of the measurement is the difference between the measured value and the true value. In general, the measured value cannot be repeated exactly, so we need a parameter that describes not only the range of the error but also how “fuzzy” or dispersed the range is. This parameter is called the uncertainty of the measured value. It gives a range, centred on the measured value, within which, to a stated probability, the true value lies. It is usual (but not universal) that the range has equal positive and negative limits.

To be meaningful, the uncertainty statement must have an associated confidence level: ie it is necessary to state the probability that the true value lies within the range given.

The reasons for choosing a 95% confidence level in this standard are:

- It is established practice throughout much of Europe, North America and Asia;
- The ISO Guide assumes that the combined uncertainty has a distribution that is a close approximation to a normal distribution. A 95% confidence level approximates to a range of 2 standard deviations. It is a widely held view that, for most measurement systems, the approximation to a normal distribution for the distribution of the combined uncertainty is reliable out to 2 standard deviations but beyond that the approximation is less reliable.
- An approximate 95% confidence interval can be simply obtained by multiplying the combined standard uncertainty by 2.

The steps to assess an uncertainty of measurement are:

- Ensure that all corrections and calibrations are correctly applied to readings;
- Construct a model of the measurement system listing all the factors that contribute error to the final result;
- Decide whether each component is to be evaluated by a Type A or Type B analysis (see the ISO Guide for details). Type A analysis uses repeat measurements and statistical means to minimise the effect of random errors and noise. Type B analysis uses an engineering approach (non-statistical methods) to estimate the worst case limits or measurement errors (based on instrument accuracy, calibration data, specifications etc. – typically data from third party sources);
- Combine all the standard uncertainty components to give an overall measurement uncertainty.

Further detail should be obtained from the ISO “Guide to the Expression of Uncertainty in Measurement”.

**Annex E**  
(Informative)

**Bibliography**  
**IEC TC59 publications for measuring energy and performance**  
**of electrical household appliances**

- IEC 60299 Household electric blankets - Methods for measuring performance
- IEC 60311 Electric irons for household or similar use - Methods for measuring performance.
- IEC 60312 Vacuum cleaners for household use - Methods of measuring the performance
- IEC 60350 Electric cooking ranges, hobs, ovens and grills for household use – Methods for measuring performance.
- IEC 60369 Methods for measuring performance of floor polishers for household and similar purposes
- IEC 60379 Methods for measuring the performance of electric storage water-heaters for household purposes.
- IEC 60436 Methods for measuring the performance of electric dishwashers
- IEC 60442 Electric toasters for household and similar purposes - Methods for measuring the performance
- IEC 60456 Clothes washing machines for household use - Methods for measuring the performance
- IEC 60508 Methods for measuring the performance of electric ironing machines for household and similar purposes
- IEC 60530 Methods for measuring the performance of electric kettles and jugs for household and similar use
- IEC 60531 Methods for measuring the performance of household electric room heaters of the storage type
- IEC 60535 Jet fans and regulators
- IEC 60619 Electrically operated food preparation appliances - Methods for measuring the performance
- IEC 60661 Methods for measuring the performance of electric household coffee makers
- IEC 60665 A.C. electric ventilating fans and regulators for household and similar purposes
- IEC 60675 Household electric direct-acting room heaters - Methods for measuring performance.
- IEC 60705 Methods for measuring the performance of microwave ovens for household and similar purposes
- IEC 60879 Performance and construction of electric circulating fans and regulators
- IEC 61121 Tumble dryers for household use - Methods for measuring the performance.
- IEC 61176 Hand-held electric mains voltage operated circular saws - Methods for measuring the performance
- IEC 61254 Electric shavers for household use - Methods for measuring the performance
- IEC 61591 Household range hoods - Methods for measuring performance